

RollEase

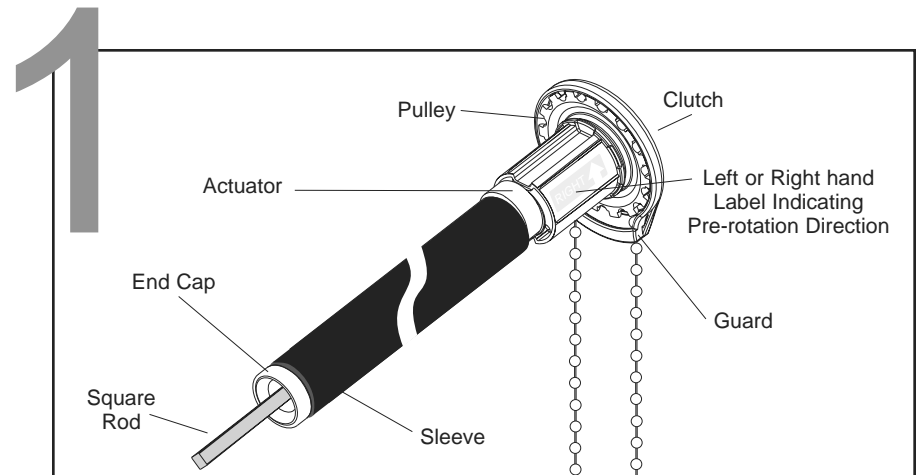

When correctly loaded with tension, the Spring Assist will reduce the pull force necessary to lift wide and heavy shades weighing up to 30 lbs. (13,5kg) (fully assembled shade) to an average of 6 lbs. (2,7 kgs)

Failure to use the correct pre-rotations may cause the system to operate improperly or may result in complete failure, breakage or personal injury.

HOW TO SELECT CORRECT PARTS

DETERMINING THE SPRING LENGTH: 36Ž (91 cm) or 45Ž (114cm)

The Spring Assist is available in either 36Ž (91 cm) or 45Ž (114cm) lengths. In order to determine which length you need as well as the proper tube diameter you must use proprietary software developed by RollEase which will tell you which parts to use and the correct number of pre-rotations needed to load the spring to the proper tension. RollEase has published Calculator Software which operates in either US or Metric values. CD part number is SACD.

Minimum hardware requirements are:

- € An IBM-compatible computer with a Pentium processor.
- € A mouse or pointing devise. 64 MB RAM minimum and CD-ROM

To use the CD you need to know these specific variables for each shade calculation:

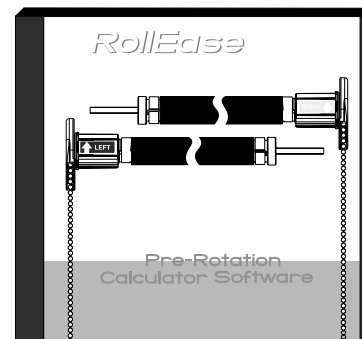

- € Fabric Weight: oz/yd² (g/m²)
- € Fabric Thickness: inches (mm)
- € Hem Bar: lb/ft (g/m)
- € Tube Diameter: inches (mm)



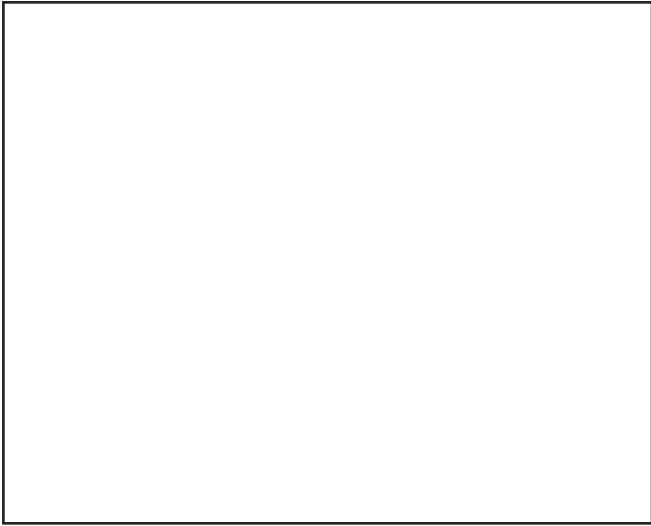

- A. Insert CD into your CD Drive.
- B. Click on •FoxheadŽ icon to launch the software.

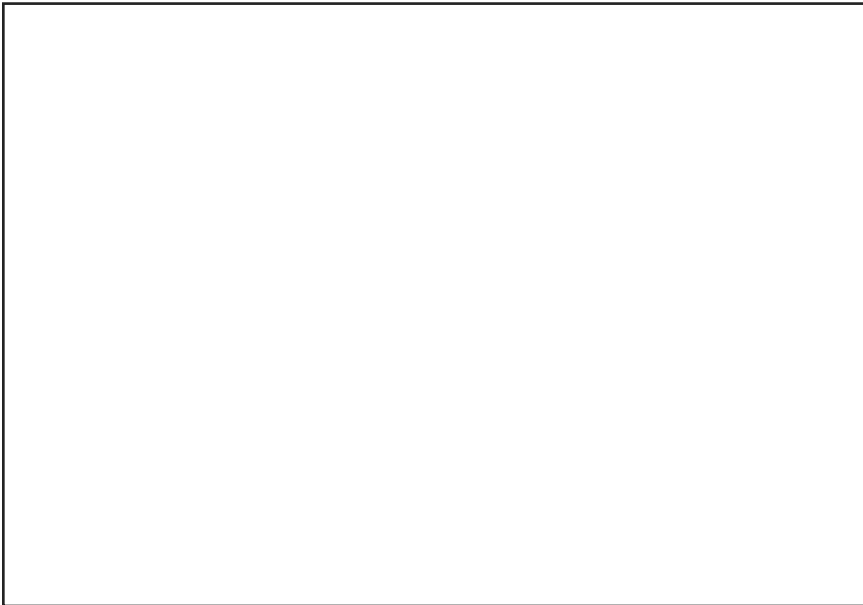

- C. Enter your shade specifications (English or Metric) and click •calculateŽ. Your answer (Spring size and pre-rotations) will appear in red text at the bottom of the screen.

Note: When using RollEase tube, simply click on •RollEase TubeŽ and the calculator will specify the proper tube size automatically.

2

SELECT LEFT OR RIGHT

STANDARD ROLL Assembly instructions assume a standard (back roll) roller shade. Select Left or Right hand clutch operation as you must use a different clutch for each side.
Assumes standard roll roller shade. For reverse roll shades see below.

LEFT-HAND clutch operation has a BLUE label on the clutch housing. The RIGHT-HAND clutch has a RED label.

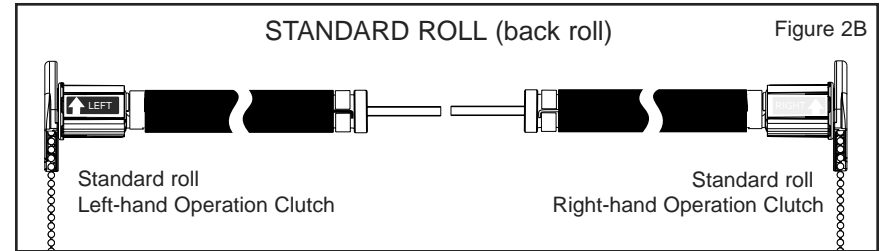

REVERSE ROLL Reverse roll roller shades must be assembled differently than standard roll above. For reverse roll roller shades (only) , use a right-hand Spring Assist on the left side or a left-hand Spring Assist on the right side. Pre-rotations should still follow the direction as indicated by the arrow.

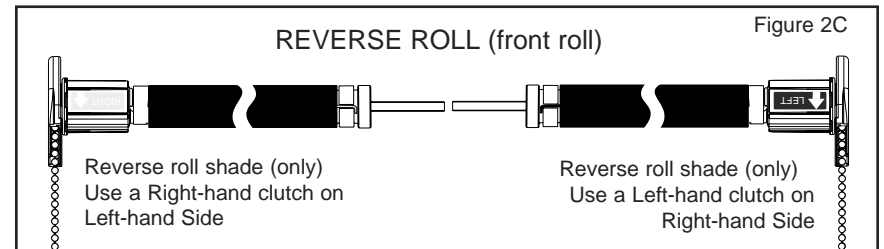

INSTALL BEAD CHAIN (Plastic or Metal)

3

- A. € Drape the desired length, closed bead chain over the clutch and onto the housing (Figure 3A).
- € Thread the bead chain into the pulley (Figure 3B) and pull the chain around the circumference until all of the chain is engaged in the pulley.
- € Pull the entire loose loop of bead chain back through the guard (Figure 3C).

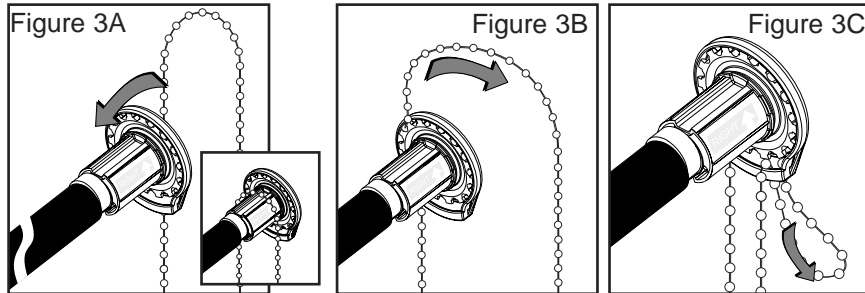

PRE-ROTATE SPRING

- A. Use the number of rotations determined in Step 1. With the clutch positioned in its operation side (Left or Right hand operation), pull on the rear chain so the housing and spring assist assembly rotate in the direction of the arrow on the red or blue sticker attached to the clutch housing....(see Figures 4A & 4B)

4

Count complete revolutions corresponding to the number of pre-rotation obtained from the correct chart or from RollEase.

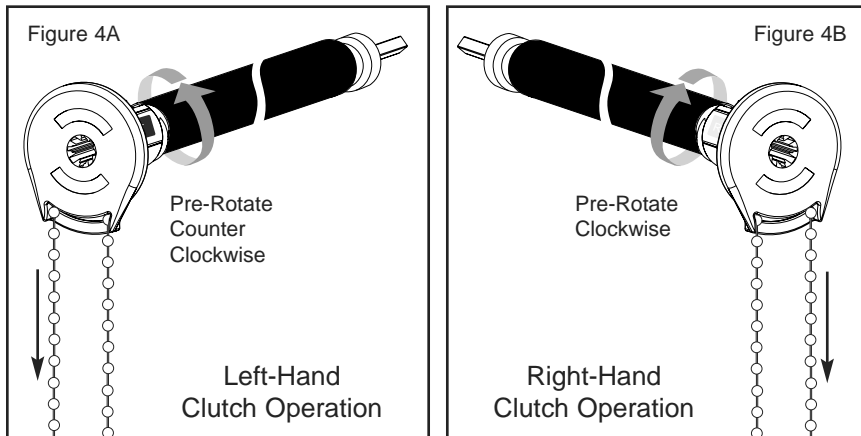

5

INSTALL SOUND REDUCING FOAM

On shade tubes with internal features (keyed tube), the end of the Spring Assist mechanism may rub against the key while the tube is rotating causing a knocking effect. To prevent this it is recommended that an approximately 1-foot (305 mm) section of common plumbing hot/cold water pipe insulation foam be taped to the black PVC sleeve on the end of the Spring Assist. (Use foam sleeve that fits 1½ (25mm) copper pipes or ¾ (75mm) iron pipes) Note: The foam sleeve must be secured to the black PVC sleeve only and should never be attached to the spring, white spring-retainer or square metal shaft.

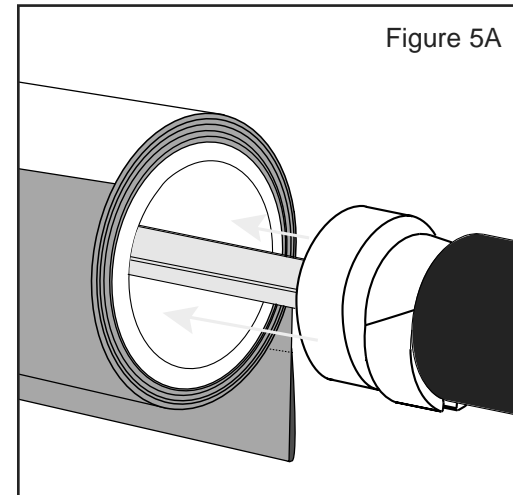

INSTALL INTO TUBE.

- A. With the shade in the rolled up position, slide the spring assist assembly into the tube until the housing on the clutch engages and it is fully seated within the tube.

Note: Make sure your roller shade is in the totally rolled-up position before inserting your Spring Assist into the tube.

MOUNT THE BRACKETS.

If the clutch is on the right end of the shade, attach the brackets to the window frame, window molding, wall or ceiling, as shown in Figures 6A, 6B and 6C.

If the clutch is on the left end of the shade, reverse the bracket positions, left for right.

TO THE INSIDE OF THE WINDOW FRAME

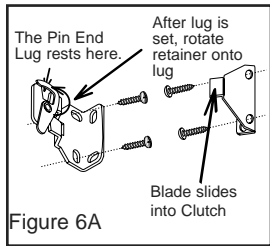

Figure 6A

TO THE WALL OR TO THE FRONT OF THE WINDOW MOLDING

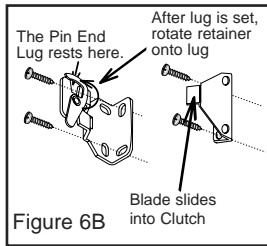

Figure 6B

TO THE CEILING OR TO THE TOP OF THE WINDOW FRAME

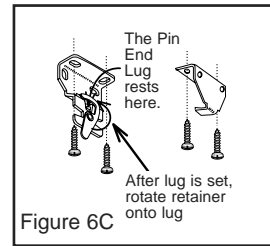

Figure 6C

6

7 INSTALL THE SHADE.

- Slide the clutch straight onto the blade of its bracket. The bottom of the clutch should always point straight down.
- Lower the lug of the end plug onto the "V" of its bracket. The roller should fit in the brackets securely, with just a little play. Rotate the riveted retainer portion to lock the lug in position.

Figure 6C

INSTALL THE TENSION DEVICE



Tension Devices reduce the hazard of strangulation and entanglement of young children by limiting access to the control cord. Anchor the Tension Device, that is attached to the shade's control cord, to the window frame or wall, so that young children cannot pull the cord around their necks.

8

- Lower the shade.
- Hold the Tension Device upright so the Warning Tag hangs straight down as shown in diagram.
- Position the Tension Device on the window frame or the wall so that the Tension Device and control cord do not interfere with raising or lowering the shade. The Tension Device should be installed without stretching or pulling down on the control cord. Stretching the cord will cause excessive wear. Do not twist or cross the control cord. If using stop balls, position the tension device 1/4 inch (0.635cm) higher to allow the stop ball to pass thru the tension device.
- Holding the Tension Device upright, and in position, as shown, insert and secure the screw through the hole. The mounting screw must be secured into a solid surface or molly.

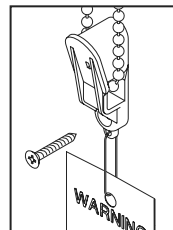

ATTACH STOPS TO A CONTROL CORD THAT'S MADE OF BEAD CHAIN.

On metal bead chain, attach a metal stop ball that is at least 5/16" inch (0.793 cm) diameter, so that it touches the mouth of the clutch when the shade is in the all-rolled-up position.

For metal or plastic bead chain, lower the shade to its required drop length, and attach the appropriate metal stop or plastic connector next to the clutch, this prevents the shade from being lowered beyond that point.

9

Note: A bead stop is recommended so the shade does not flip over at the top or hang with the tube exposed and possibly having the shade fall off the tube. If the shade flips over the top and the shade is subsequently lowered, the spring assist will start to reverse itself and may cause the system to be inoperative.

NOTES

Re-setting Spring To Zero

If it ever becomes necessary to reset the spring assist to zero tension (ie...changing a spring assist roller shade for use in another application, etc...) before adding additional pre-rotations you need to make sure the spring tension is reset to zero.

How to tell if spring is at zero tension: Hold the clutch by the housing with one hand and with the other move the cord guard and release. If the cord guard stays in its position the spring is virtually at zero, if the cord guard snaps back, adjustment is needed. Manually adjust as close to zero as possible using the bead chain to counter rotate the spring in the opposite direction of the arrow. Test and adjust until the spring is at zero.

Once the spring has returned to zero, use the pre-rotation chart, and pre-wind the spring according the requirements of the new application.

